

Jednostranné svodidlo
Single-sided safety barrier

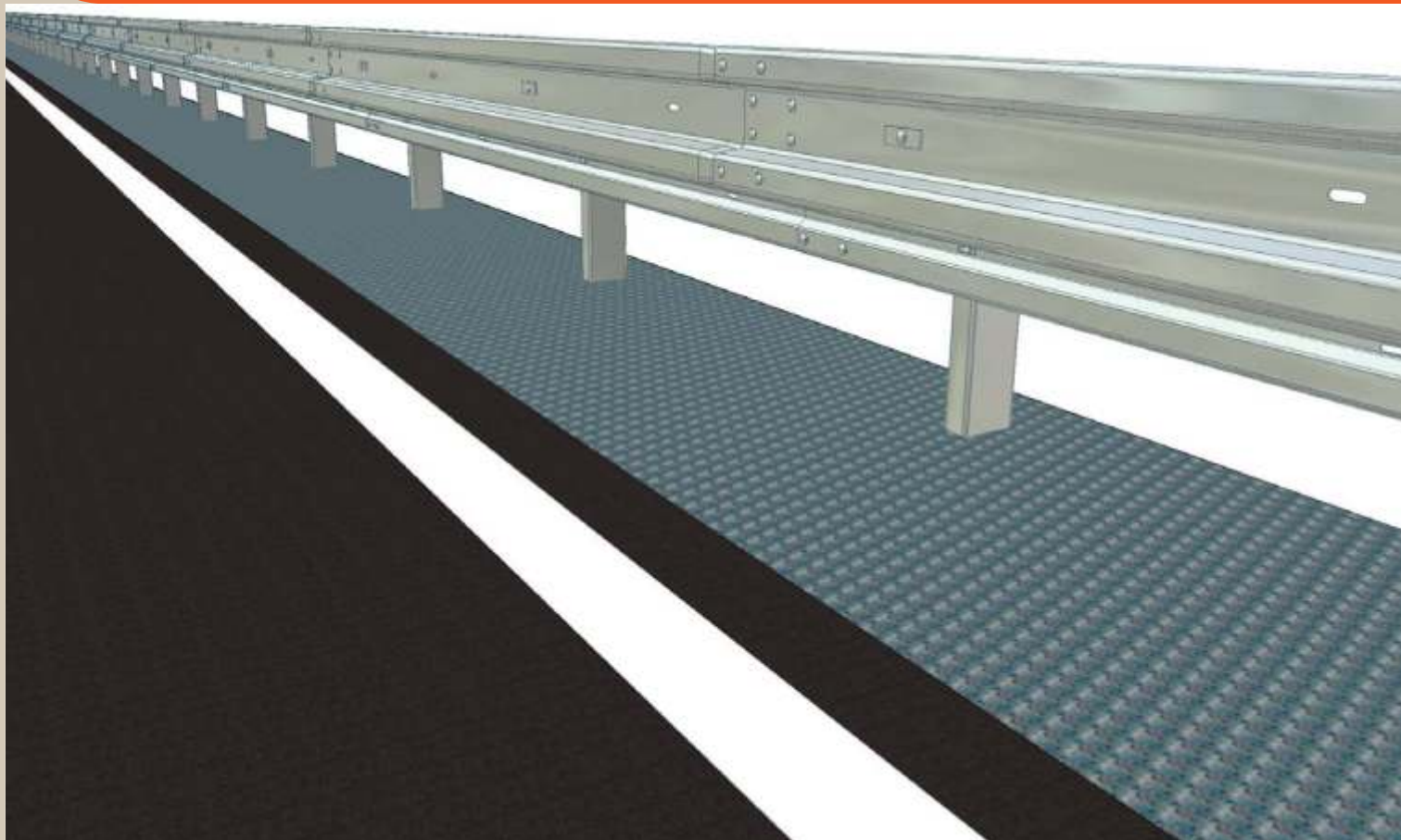

ArcelorMittal

JSAM-2/H2



Úroveň zadržení
Containment level

H2

Test EN 1317



TB 11 900 kg; 100 km/h



TB 51 13 000 kg; 70 km/h

Index prudkosti nárazu
Acceleration severity index

B

ASI = 1,1

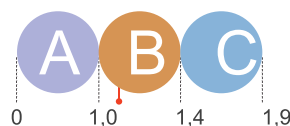

Pracovní šířka
Working width

W5

W=1,6 m, D=1,5 m

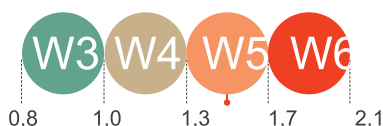

Hmotnost systému
System weight

29,00 kg/m

Jednostranné svodidlo
Single-sided safety barrier

JSAM-2/H2

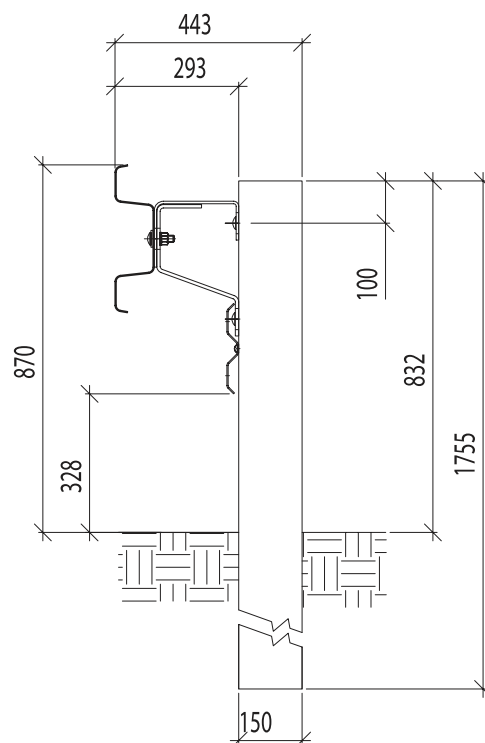
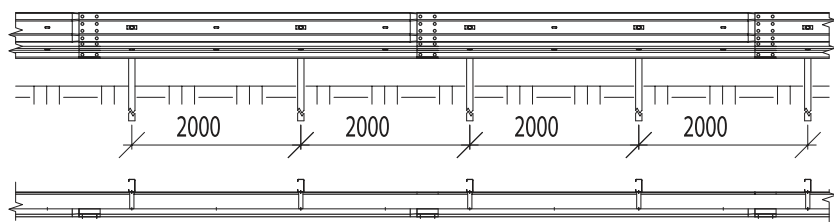
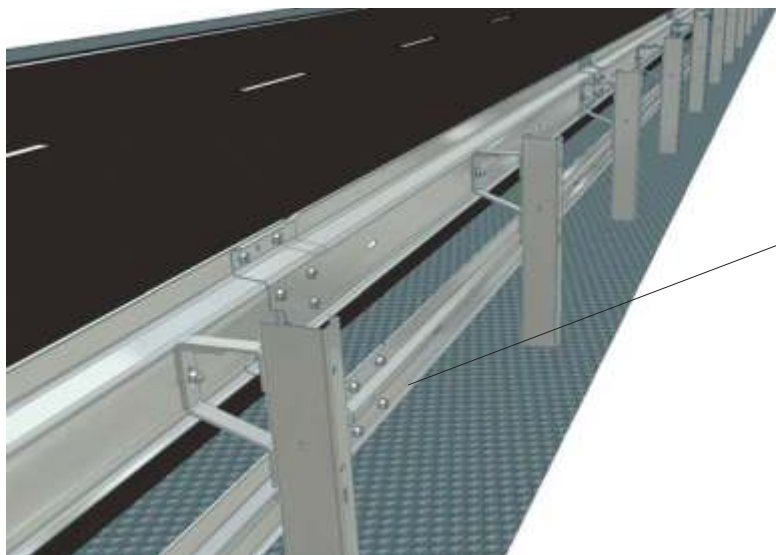

Název dílu	Pozice Position	Materiál Material	Číslo dílu Component No.	Ks/4m Pcs/4m	Designation
Svodnice AM	1	S355MC	60.0.00	1	Barrier strip AM
Spodní pásnice AM	2	S355MC	60.0.20	1	Lower beam AM
Sloupek C150x75x25-1755	3	S420MC	61.3.00	2	Post C150x75x25 - 1755
Distanční díl NH4 V	4	S235JR	52.0.12	2	Spacer NH4 V
Distanční díl NH4 VI	5	S235JR	52.0.13	2	Spacer NH4 VI

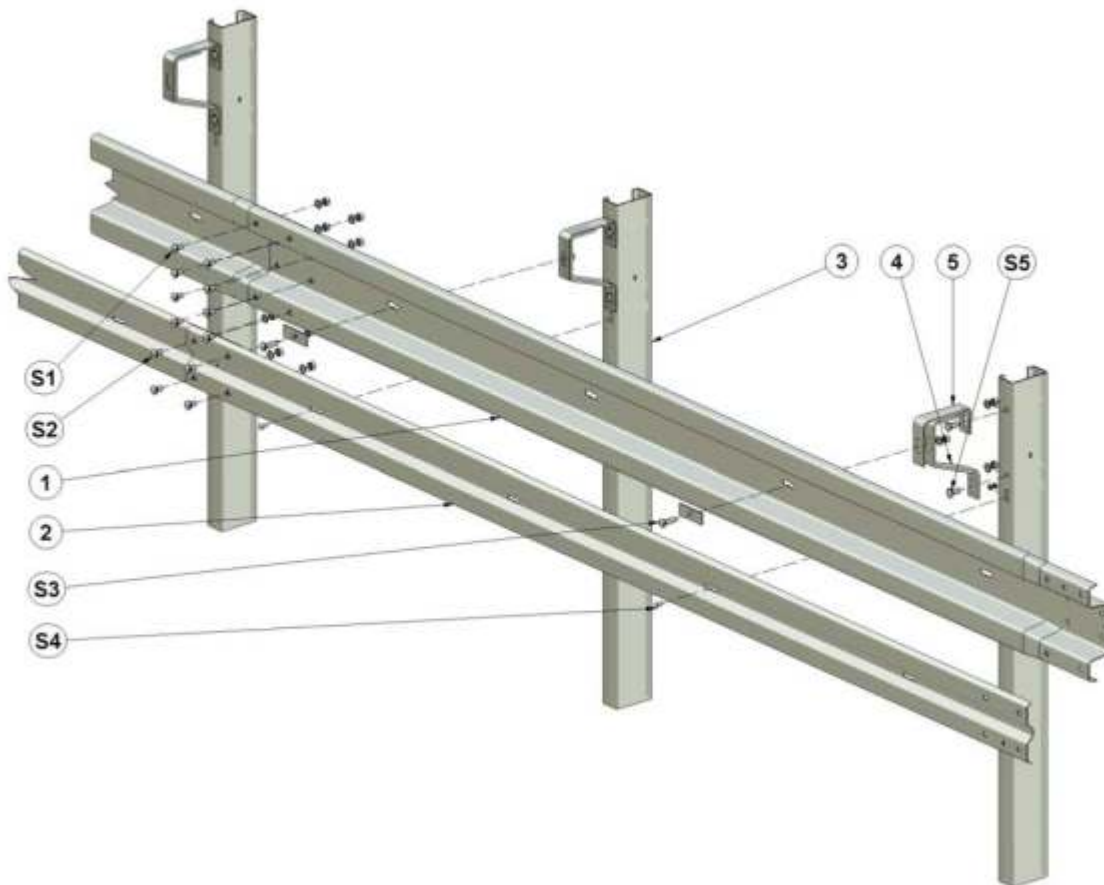

Název dílu	Pozice Position	Číslo dílu Component No.	Ks/4m Pcs/4m	Designation
Šroub s polokruhovou hlavou a noseM M16x30-4.6-tZn		59.0.80	8	Cup nib bolt M16x30-4.6-tZn
Podložka 17,5-tZn (ø 30/17,5/3)	ø 30/17,5/3) S1	59.4.40	8	Washer 17.5-tZn (
Matice M 16 - 6 – tZn ISO 4032		59.2.40	8	Nut M16-6-tZn ISO 4032
Šroub s polokruhovou hlavou a noseM M16x30-4.6-tZn		59.0.80	4	Cup nib bolt M16x30-4.6-tZn
Podložka 17,5-tZn (ø 30/17,5/3)	ø 30/17,5/3) S2	59.4.40	4	Washer 17.5-tZn (
Matice M 16 - 6 – tZn ISO 4032		59.2.40	4	Nut M16-6-tZn ISO 4032
Šroub s polokruhovou hlavou a noseM M16x55-4.6-tZn		59.0.82	2	Cup nib bolt M16x55-4.6-tZn
Krycí podložka M16		59.4.80	2	Backplate M16
Podložka 17,5-tZn (ø 30/17,5/3)	ø 30/17,5/3) S3	59.4.40	2	Washer 17.5-tZn (
Matice M 16 - 6 – tZn ISO 4032		59.2.40	2	Nut M16-6-tZn ISO 4032
Šroub s polokruhovou hlavou a noseM M10x25-4.6-tZn		59.0.60	2	Cup nib bolt M10x25-4.6-tZn
Podložka 11-tZn (ø 11/21/2,5)	ø 21/11/2,5) S4	59.4.00	2	Washer 11-tZn (
Matice M 10 - 6 – tZn ISO 4032		59.2.00	2	Nut M10-6-tZn ISO 4032
Šroub s polokruhovou hlavou a noseM M16x40-4.6-tZn		59.0.81	4	Cup nib bolt M16x40-4.6-tZn
Podložka 17,5-tZn (ø 30/17,5/3)	ø 30/17,5/3) S5	59.4.40	4	Washer 17.5-tZn (
Matice M 16 - 6 – tZn ISO 4032		59.2.40	4	Nut M16-6-tZn ISO 4032

