

Oboustranné svodidlo  
Double-sided safety barrier

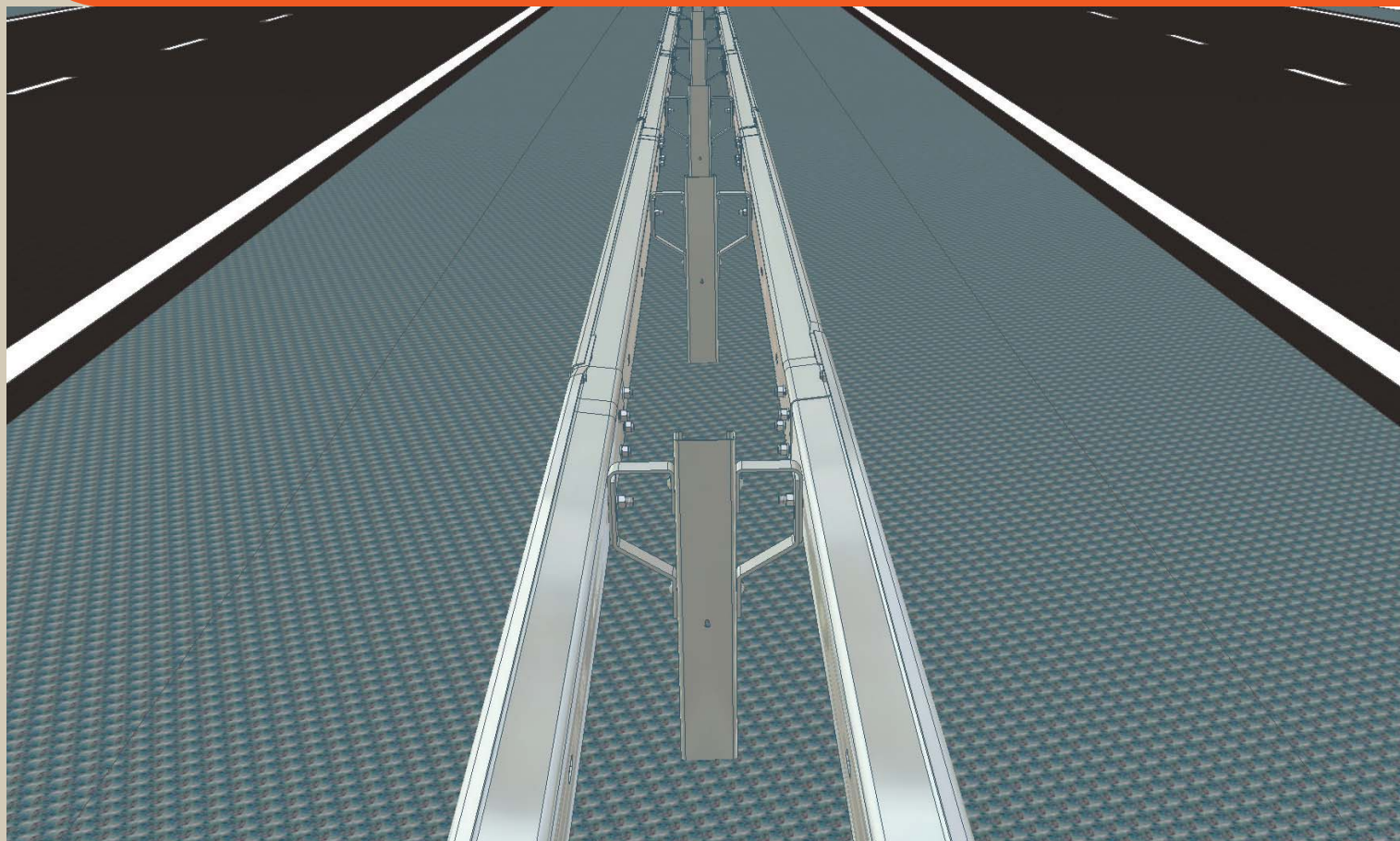

ArcelorMittal

# OSAM/H1



Úroveň zadržení  
Containment level

H1

Index prudkosti nárazu  
Acceleration severity index

A

Test EN 1317

 TB 11 900 kg; 100 km/h

 TB 42 10 000 kg; 70 km/h

ASI = 0,776



Pracovní šířka  
Working width

W5

W=1,38 m, D=1,12 m



Hmotnost systému  
System weight

32,37 kg/m

Oboustranné svodidlo  
Double-sided safety barrier

# OSAM/H1

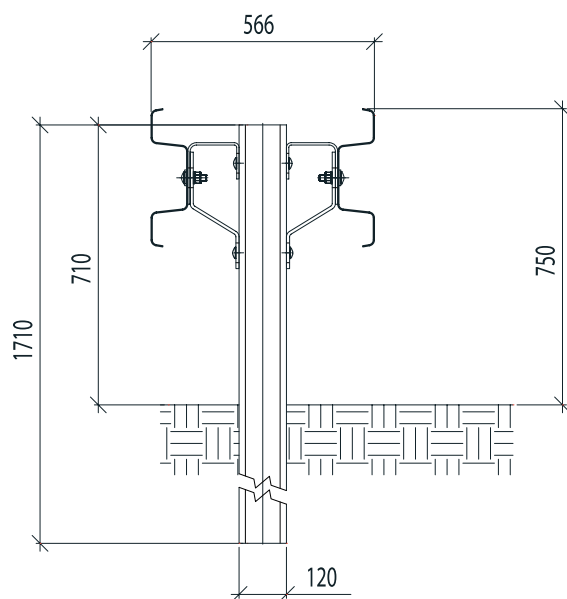
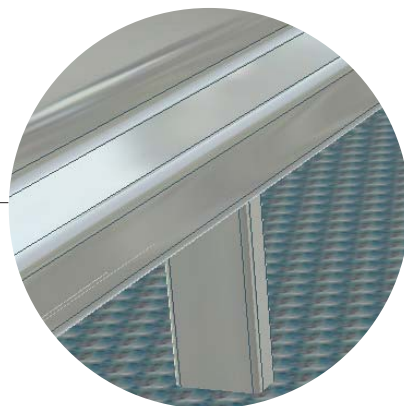
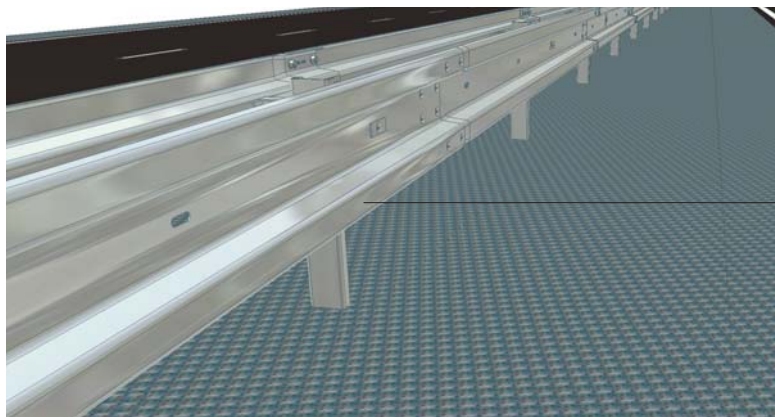

Název dílu	Pozice Position	Materiál Material	Číslo dílu Component No.	Ks/4m Pcs/4m	Designation
Svodnice AM	1	S355MC	60.0.00	2	Barrier strip AM
Sloupek C120 střední 1710	2	S420MC	61.1.00	1.33	Middle post C120 1710
Distanční díl JM1	3	S355JR	62.0.00	2.67	Spacer JM1
Distanční díl JM2	4	S355JR	62.0.01	2.67	Spacer JM2

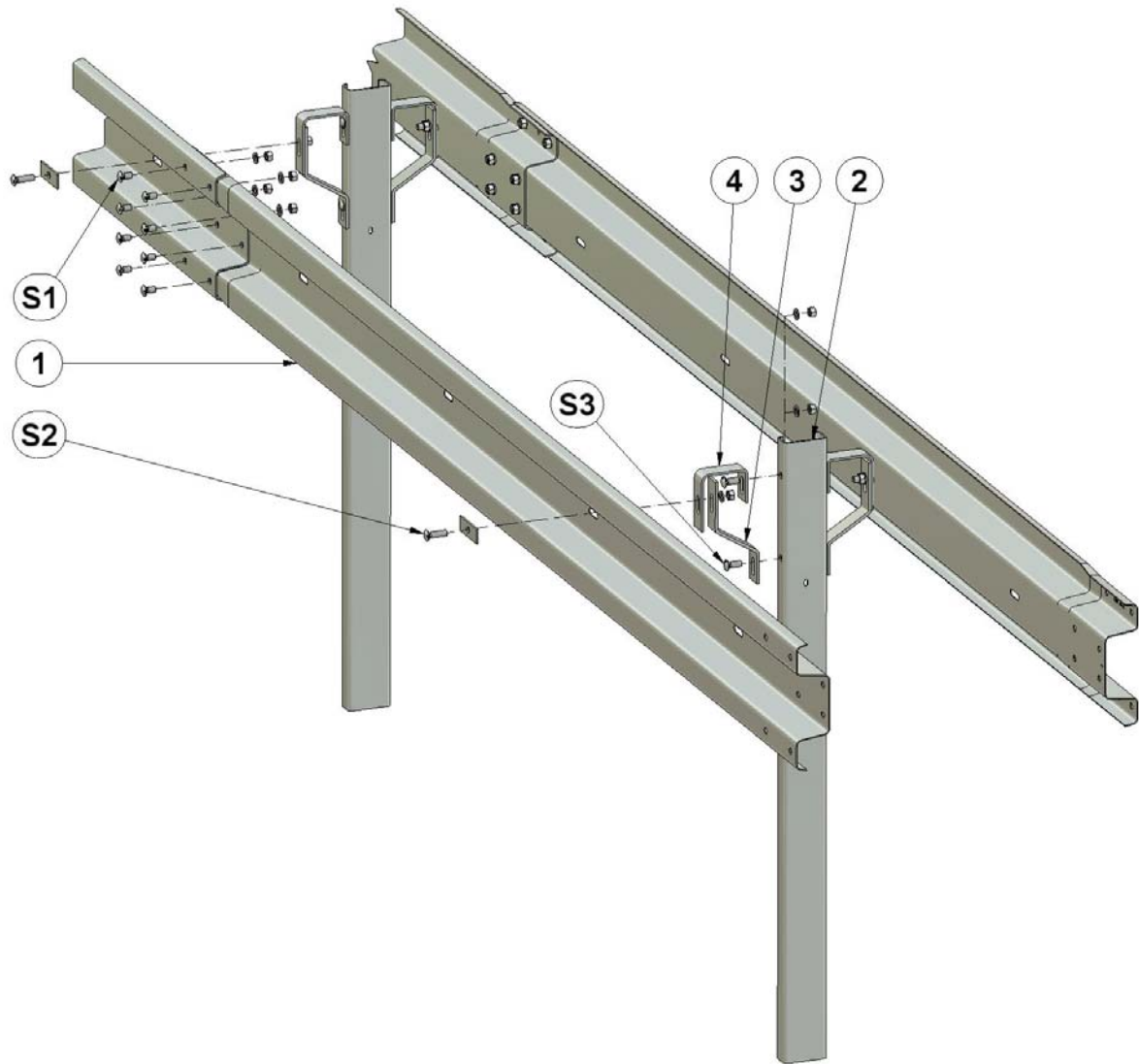

Název dílu	Pozice Position	Číslo dílu Component No.	Ks/4m Pcs/4m	Designation
Šroub s polokruhovou hlavou a nosem M16x30-4.6-tZn	S1	59.0.80	16	Cup nib bolt M16x30-4.6-tZn
Podložka 17,5-tZn (ø 30/17,5/3)		59.4.40	16	Washer 17.5-tZn (ø 30/17,5/3)
Matice M 16 - 6 - tZn ISO 4032		59.2.40	16	Nut M16-6-tZn ISO 4032
Šroub s polokruhovou hlavou a nosem M16x55-4.6-tZn	S2	59.0.82	2.67	Cup nib bolt M16x55-4.6-tZn
Krycí podložka M16		59.4.80	2.67	Backplate M16
Podložka 17,5-tZn (ø 30/17,5/3)		59.4.40	2.67	Washer 17.5-tZn (ø 30/17,5/3)
Matice M 16 - 6 - tZn ISO 4032	S3	59.2.40	2.67	Nut M16-6-tZn ISO 4032
Šroub s polokruhovou hlavou a nosem M16x40-4.6-tZn		59.0.81	5.33	Cup nib bolt M16x40-4.6-tZn
Podložka 17,5-tZn (ø 30/17,5/3)		59.4.40	5.33	Washer 17.5-tZn (ø 30/17,5/3)
Matice M 16 - 6 - tZn ISO 4032		59.2.40	5.33	Nut M16-6-tZn ISO 4032

Oboustranné svodidlo  
Double-sided safety barrier

OSAM/H1

  
ArcelorMittal

Zádržný systém byl testován  
a certifikován podle řady norem  
EN 1317.

Všechny díly jsou zároveň zinkovány  
podle EN ISO 1461:2009

Restraint system was tested and  
certified in accordance with the  
standards EN 1317.

All parts are hot dip galvanized  
in accordance with the  
EN ISO 1461:2009



ArcelorMittal Distribution Solutions  
Czech Republic, s. r. o.  
Vratimovská 689  
707 02 Ostrava-Kunčice  
Czech Republic

T +420 595 682 625  
+420 595 686 524  
+420 595 684 590  
+420 595 685 627  
F +420 595 686 379

E sales.sb@arcelormittal.com  
[www.arcelormittal.com](http://www.arcelormittal.com)